

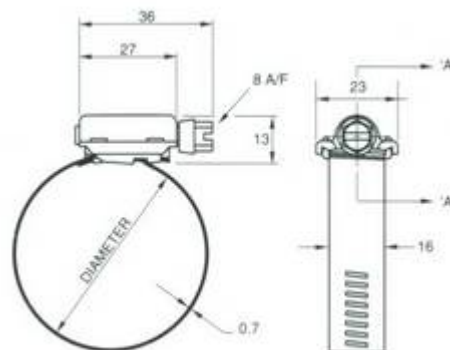

# High Torque

For applications requiring extra high levels of tightening torque

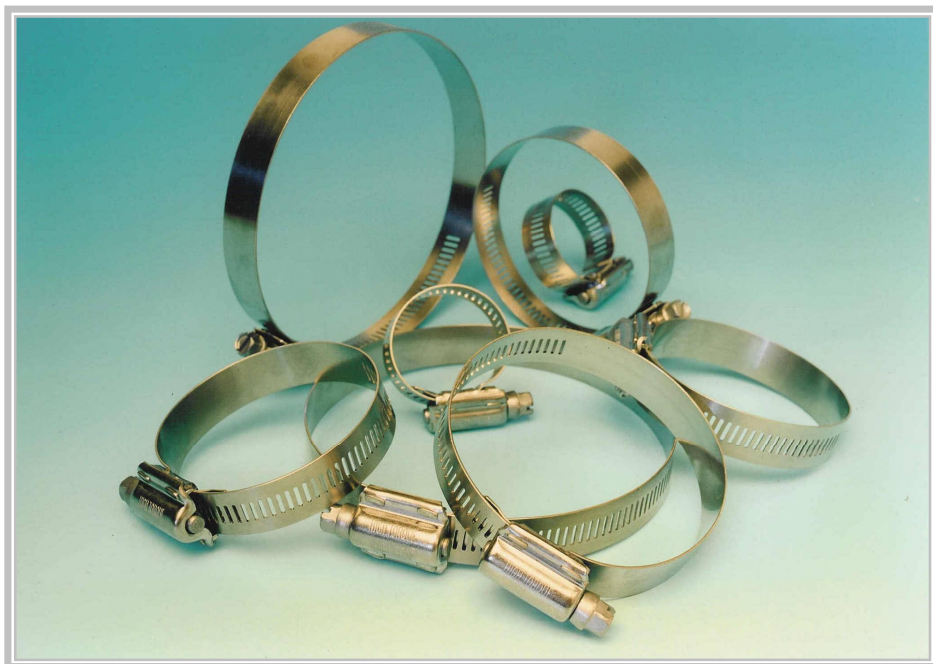

All dimensions in mm

SECTION 'A-A'



Screw threads fully engaged

- Twice the tightening torque of standard worm drive hose clips which creates more than twice the band tension for those stubborn leakage and high vibration applications.
- All stainless steel construction.
- Breaking torque of Jubilee high torque is comparable to conventional 'T' bolt clamp of equal size.
- Recommended tightening torque 17 Nm (150 lb in).
- Jubilee High Torque clips for applications that require extra high levels of tightening torque.
- They can be used on hose applications such as spiral wound wire reinforced suction hose.
- High Torque clips are appropriate in those heavy duty situations where the general British Standard product is not suitable.

Ask our Sales Department for further information.

### MATERIAL SPECIFICATION

#### Stainless Steel

Band: BS/AISI 304 A2  
 Housing: BS/AISI 304 A2  
 Screw: BS/AISI 410

| Size No. | Working Diameter |                 | Box Quantities |
|----------|------------------|-----------------|----------------|
|          | mm               | Inches          |                |
| 35       | 20- 35           | 3/4 - 1 3/8     | 50             |
| 40       | 25- 40           | 1 - 1 5/8       | 50             |
| 45       | 25- 45           | 1 - 1 3/4       | 50             |
| 50       | 30- 50           | 1 1/4 - 2       | 50             |
| 70       | 40- 70           | 1 5/8 - 2 3/4   | 50             |
| 80       | 60- 80           | 2 3/8 - 3 1/8   | 50             |
| 95       | 70- 95           | 2 3/4 - 3 3/4   | 50             |
| 100      | 80-100           | 3 1/8 - 4       | 50             |
| 120      | 90-120           | 3 1/2 - 4 3/4   | 50             |
| 140      | 110-140          | 4 3/8 - 5 1/2   | 50             |
| 160      | 130-160          | 5 1/8 - 6 1/4   | 50             |
| 180      | 150-180          | 5 7/8 - 7       | 50             |
| 200      | 170-200          | 6 3/4 - 7 7/8   | 25             |
| 220      | 190-220          | 7 1/2 - 8 5/8   | 25             |
| 240      | 210-240          | 8 1/4 - 9 1/2   | 25             |
| 260      | 230-260          | 9 - 10 1/4      | 25             |
| 280      | 250-280          | 9 7/8 - 11      | 25             |
| 300      | 270-300          | 10 5/8 - 11 3/4 | 25             |
| 320      | 290-320          | 11 3/8 - 12 1/2 | 25             |
| 340      | 310-340          | 12 1/4 - 13 3/8 | 25             |
| 360      | 330-360          | 13 - 14 1/8     | 25             |
| 380      | 350-380          | 13 3/4 - 15     | 25             |
| 400      | 370-400          | 14 1/2 - 15 3/4 | 25             |
| 420      | 390-420          | 15 3/8 - 16 1/2 | 25             |
| 440      | 410-440          | 16 1/8 - 17 1/4 | 25             |
| 460      | 430-460          | 17 - 18 1/8     | 25             |
| 480      | 450-480          | 17 3/4 - 18 7/8 | 25             |
| 500      | 470-500          | 18 1/2 - 19 5/8 | 25             |



**HIGH TORQUE** AVAILABLE FROM:-

L Robinson & Co. (Gillingham) Ltd., Owens Way, Gads Hill, Gillingham, Kent, ME7 2RS, England.

Tel: +44 (0) 1634 281200 Fax: +44 (0) 1634 280101 Email: sales@jubileeclips.co.uk Website: www.jubileeclips.co.uk