

Type LC

Malleable iron, bright zinc plated

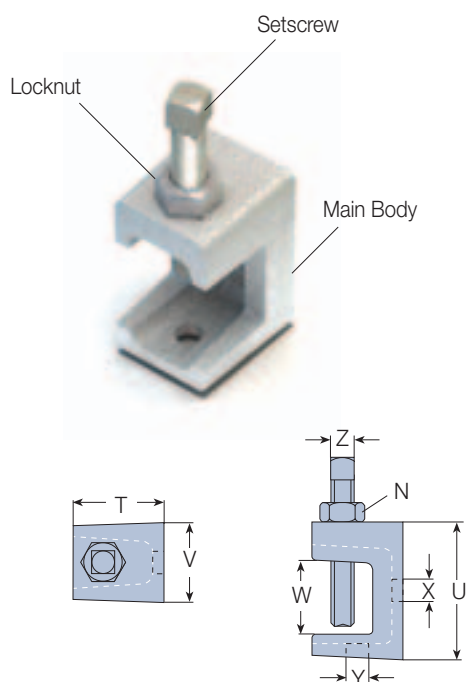

Beam clamp with tapped holes in position X and Y to accept threaded rod or cable clips. For parallel or tapered flanges. Supplied with grade 8.8 cup point setscrew.

➤ Installation see page 56 – type FL

Product Code	Thread		Safe Working Load (4:1 Factor of Safety)		Clamping Thickness W mm	Setscrew Z	Torque		Dimensions		
	X	Y	Tensile / in Pos. X kN	Tensile / in Pos. Y kN			Setscrew Z Nm	Locknut N Nm	T mm	U mm	Width V mm
LC06	M6	M6	0.18	0.59	3 - 20	M6	4	4	25	36	21
LC08	M8	M8	0.18	0.59	3 - 20	M6	4	4	25	36	21

■ Order example: LC06

Type SW - Swivel Unit

High Grade Alloy Steel, bright zinc plated

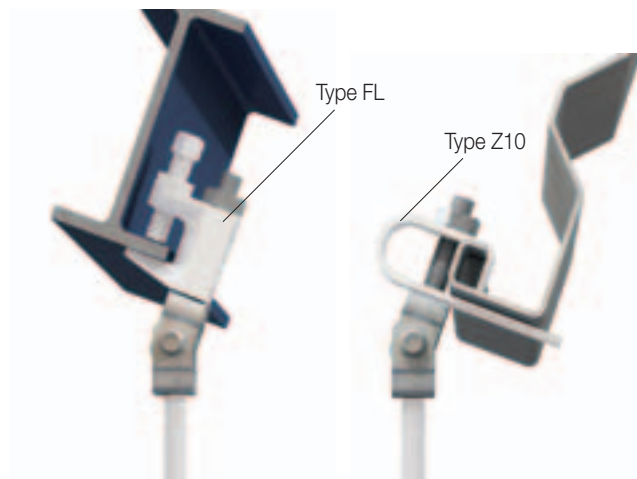
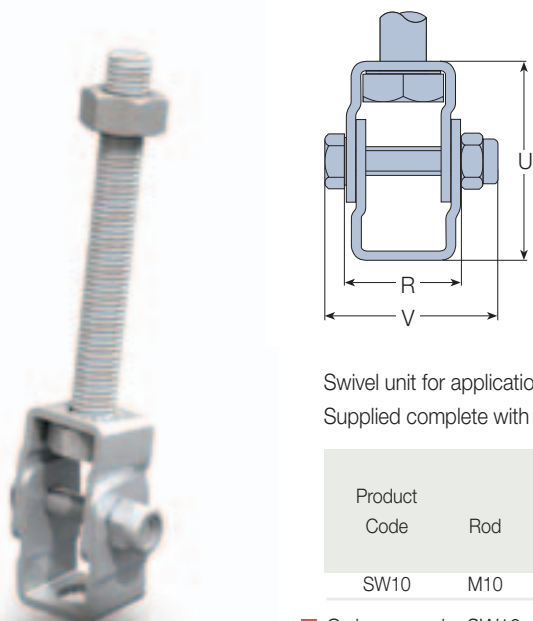

Swivel unit for applications on inclined beams. Can be used with type FL or type Z10. Supplied complete with grade 8.8 M10 x 90 setscrew and nut.

Product Code	Rod	Safe Working Load (4:1 Factor of Safety)		Rotation	Torque Nm	Dimensions		
		Tensile kN	Max. Inclination			U mm	R mm	Width V mm
SW10	M10	2.4	18°	360°	11	45	25	35

■ Order example: SW10